



Cryogen Free Superconducting Magnet Systems

CRYO
INDUSTRIES

CRYO Industries of America, Inc. 11124
S. Willow St. • Manchester, NH 03103
Tel: (603) 621-9957 • Fax: (603) 621-9960
E-mail: cryo@cryoindustries.com



CRYO

Cryo Industries of America, Inc. has over 25 years of experience in designing and manufacturing Superconducting Magnet Systems. Custom designs are our specialty!

Cryo offers Closed Cycle Superconducting Magnet Systems that integrate innovative design with magnetic fields that range from 2 Tesla up to 19 Tesla (depending on design), you select the magnetic field. Magnet configurations available include Vertical Field Solenoid or Horizontal Field Split Coil magnets.

Cryo offers Superconducting Magnet designs with a clear vertical room temperature bore or a top loading variable temperature insert or both. The magnet is cooled through a Gifford-McMann cooler or a Pulse Tube cooler for low vibration experiments.

All complete Superconducting Magnet Systems include:

- Conductivity cooled superconducting magnet
- Removable room temperature bore or variable temperature insert
- Closed cycle refrigerator (G-M or pulse tube)
- Compressor
- Programmable reversing bipolar magnet power supply
- Integral energy absorber
- Temperature controller
- Temperature sensor(s).

Cryo Industries's 'performance by design' Superconducting Magnet Systems offers many field tested and proven designs throughout the scientific community. Cryo is able to offer continued technical support for the life of the system.

CRYO

This innovative design allows for many different configurations, including a compact size or various stand options. See photo below.

Conductively Cooled Superconducting Magnet System with Variable Temperature Insert

Reference Drawing No.: CF-500

- You select the magnet field at 4.2K
- Temperature operating range of <5K to 325K
- +0.5% homogeneity over central 1 cm DSV
- <100 amps nominal operating current
- Quench protection installed
- HTS (High Temperature Superconductor) magnet current leads
- Integral Variable Temperature Sample Insert
- (2.00 inch) clear axial bore diameter
- Charcoal cryopump assembly
- CalFit Cernox (4K to 325K) temperature sensor installed on magnet
- Platinum temperature sensor installed on 1st stage of refrigerator
- CalFit Cernox (4K to 325K) temperature sensor installed on 2nd stage of refrigerator
- 1.25 inch O.D. (30.7 mm I.D.) sample tube
- Sample probe with rotational and linear adjustments
- Heater installed on sample mount
- Calibrated (4K to 325K) Cernox temperature sensor installed on sample mount
- (2) 10-pin electrical sample feedthroughs
- Copper Resistivity sample holder with 8-pins
- Sample exchange gas valve with safety pressure relief
- Gate valve
- Sample change housing with evacuation valve and pressure relief
- 1.0 Watt closed cycle refrigeration & compressor
- 4K closed cycle Sumitomo refrigerator with 1.0 watt at 4.2K for magnet cooling
- Water cooled compressors with interchanging hoses

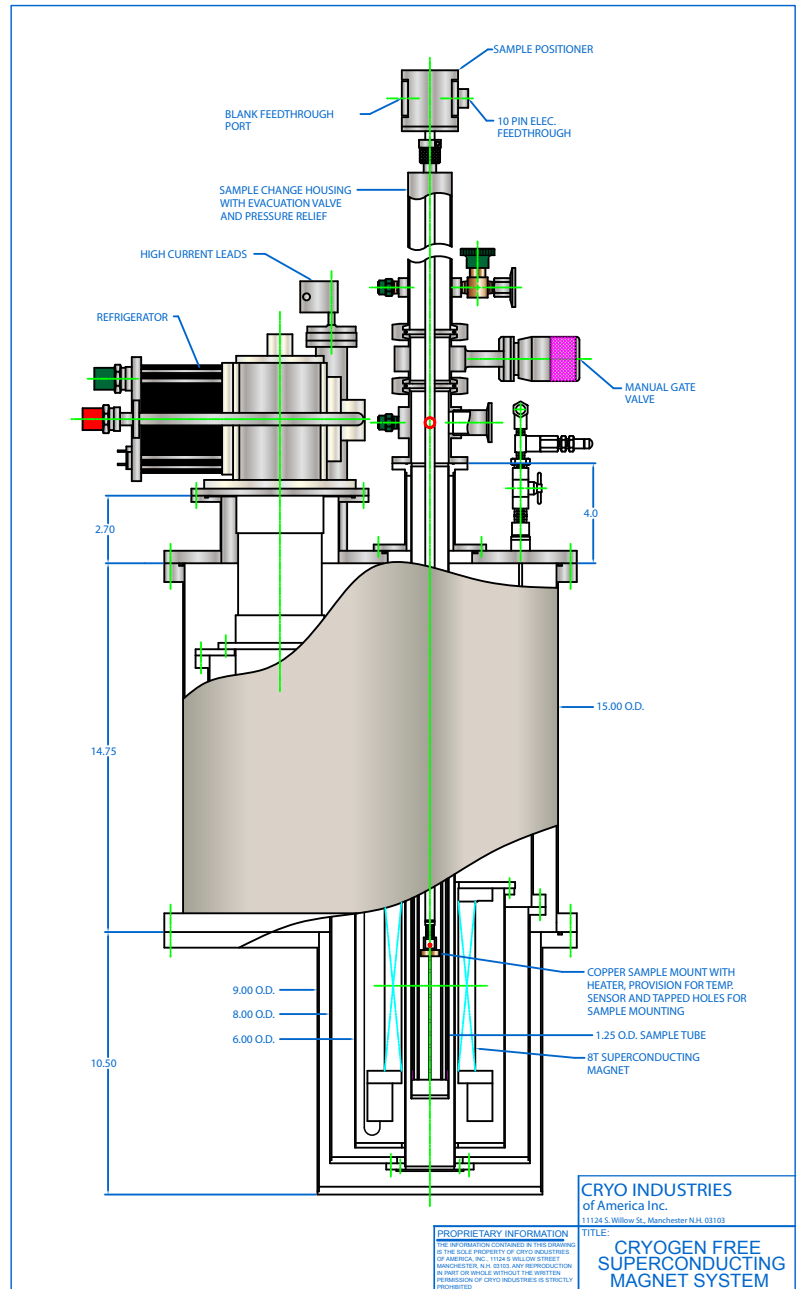

CRYO Industries of America, Inc. 11124 S. Willow St. • Manchester, NH 03103
Tel: (603) 621-9957 • Fax: (603) 621-9960
E-mail: cryo@cryoindustries.com

CRYO

This innovative design features a Room Temperature Bore, which allows for optional Variable Temperature Insert. Run the system in either configuration. See photo below.

Conductively Cooled Superconducting Magnet System with Room Temperature Bore

SYSTEM FEATURES:

Reference Drawing: CF-2376-RTB

- You select the magnetic field at 4.2 K
- +/-0.1% central field homogeneity over a 10 mm DSV
- <60 amps nominal operating current
- Quench protection installed
- HTS (High Temperature Superconductor) magnet current leads
- 3.03 inch Diameter Room Temperature Bore (RTB)
- Charcoal cryopump assembly
- CalFit Cernox (4K to 325K) temperature sensor installed on magnet 1.0 Watt closed cycle refrigerator and compressor
- 4K closed cycle Sumitomo refrigerator with 1.0 watt at 4.2K for magnet cooling
- Water cooled compressor with interchanging hoses
- Radiation shield conduction cooled by GM 1st stage
- Charcoal getter for vacuum integrity
- Pressure relief valve
- Hermetically sealed electrical feedthroughs
- Evacuation valve with NW25 flange
- System operates without liquid cryogenes
- Start up tool kit with operational manual
- 1 Year warranty

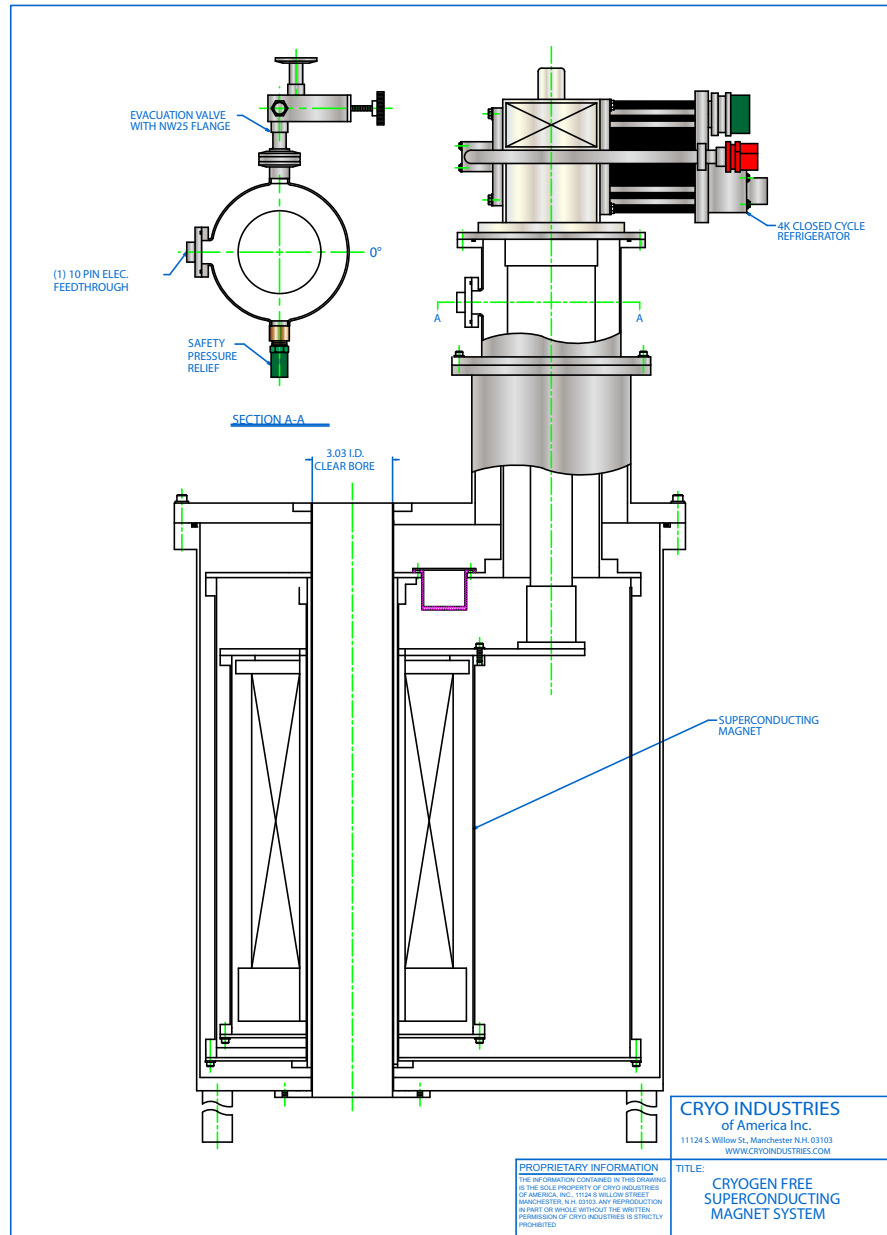

CRYO Industries of America, Inc. 11124
S. Willow St. • Manchester, NH 03103
Tel: (603) 621-9957 • Fax: (603) 621-9960
E-mail: cryo@cryoindustries.com

CRYO

Cryo Industries through our team of physicists and engineers is able to custom design a Superconducting Magnet System that meets your specifications. We also offer many systems to meet any experimental need, such as Mossbauer. Below are examples of some of the innovative, custom designs that Cryo has manufactured.



CRYO Industries of America, Inc. 11124
S. Willow St. • Manchester, NH 03103
Tel: (603) 621-9957 • Fax: (603) 621-9960
E-mail: cryo@cryoindustries.com

A versatile cryocooled 15 T superconducting magnet with a room-temperature bore and an optical window

George Svenconis⁺, Leong Ying⁺, A. R. Raju[#] and C. N. R. Rao^{#,*}

⁺Cryo Industries of America, Inc., 11124 South Willow Street, Manchester, NH 03103, USA

[#]Chemistry and Physics and Materials Unit, Jawaharlal Nehru Centre for Advanced Scientific Research, Jakkur, P. O., Bangalore 560 064, India

A close-cycle cryocooled Nb₃Sn superconducting magnet, using a single coil along with leads of the 2223 bismuth cuprate high-temperature superconductor, has been designed and fabricated. The magnet achieves a field up to 15 T and has a roomtemperature bore of 52 mm as well as an optical window. The cooling-down time from room temperature to 3.5 K is 13 h. The maximum field attainable is 15 T for 3 h and 14.5 T for continuous use. This magnet will be specially useful in laboratories where liquid helium is not readily available.

SUPERCONDUCTING magnets employing Nb₃Sn coils immersed in liquid helium are continuously used to attain high magnetic fields¹. The connecting leads in these magnets are made up of copper wires. Due to heat losses through the leads, these magnets consume large quantities of liquid helium. After the discovery of high T_c superconducting materials, the copper leads are being replaced by the high T_c ceramic superconductor leads, to reduce thermal losses up to 90%. Close-cycle refrigerator systems reaching 4.2 K with a cooling capacity of 1.0 W at 4.2 K have been fabricated by employing solid state conduction cooling. From the engineering point of view, one can design a superconducting magnet by employing the conventional Nb₃Sn coils and high T_c superconductor leads so that the magnet can work without liquid helium. An important requirement in superconducting magnets is a room-temperature bore, essential for researchers working at high temperatures, but this is difficult to achieve in the conventional immersion type technology. What would be most useful is to have a magnet that can produce high magnetic fields without liquid helium, and which also has a roomtemperature bore. Such a magnet will also alleviate problems faced with the non-availability of liquid helium in many countries. A key element in designing such a magnet is the use of high T_c superconductor leads along with a cryocooled system such as the Gifford

McMahon (GM) refrigeration cycle to cool the coil to 4.2 K. To this end, there have been efforts to make cryocooled superconducting magnets with the NbTi wires to achieve fields of the order of 9 T or lower^{2,3}.

Cryocooled superconducting magnets⁴⁻⁷ described in the recent literature, employ a three-coil system, since currents of the order of 240 amps cannot be passed to achieve fields of 15 T or more. The size of the magnet and the thermal loss in these designs have also been large. In order to compensate for the losses, two cryocooled refrigerators of 1.0 W at 4.2 K capacity have been employed, but this increases the weight as well as the cost of the magnet considerably. We have been able to design and fabricate a versatile magnet giving fields up to 15 T, by employing Nb₃Sn wire, high T_c Bi₂Sr₂Ca₂CU₃O₁₀ (2223) leads and a close-cycle cryocooled helium refrigerator of 1 W at 4.2 K with several useful features.

Unique features of the magnet

The following are the unique features of the magnet designed and fabricated by us.

- (a) a single Nb₃Sn coil instead of two or three coils,
- (b) cooling-down time from room-temperature to 3.5 K of 13 h instead of 100 h or more as in the earlier designs,
- (c) small size and low cost of the magnet by employing a single close-cycle cryocooled system,
- (d) incorporation of a persistent switch to use the magnet in a persistent mode,
- (e) a room-temperature bore to carry out magnetoresistance and other measurements from 12 K to 500 K, and
- (f) an optical window to carry out measurements under illumination with an appropriate radiation. In what follows, we describe the essential aspects of the design and fabrication.

*For correspondence. (e-mail: enrroa@jncasr.ac.in)

Table 1. Specifications of the Nb₃Sn wire and magnet coil

Specification	Value
Diameter of the wire	1.0 mm
Current carrying capacity at 15 T (4.2 K)	300 amps
Coil through bore diameter	52.4 mm
Overall diameter of the coil	121.0 mm
Overall length	200.0 mm
Distance from base to field centre	97.5 mm

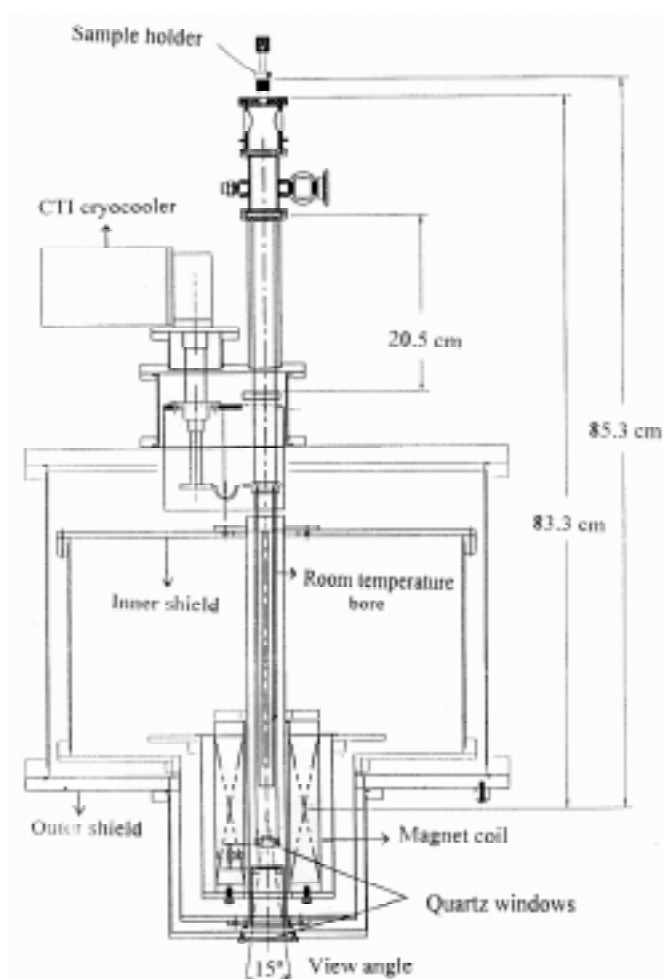
**Figure 1.** Schematic diagram showing the cross-sectional view of 15 T magnet and resistivity measurements arrangement.

Design and fabrication

In the design of the magnet, we have adopted a single-coil system by carefully choosing a Nb₃Sn multifilamentary core of 1.0 mm diameter, fabricated by the modified Jelly Roll process, with 53% copper content to allow easy heat dissipation so that current up to 240 amps can be passed. The specifications of the Nb₃Sn wire used by us are listed in Table 1. This wire also helps to restrict the coil temperature below 60 K when coil-quench oc-

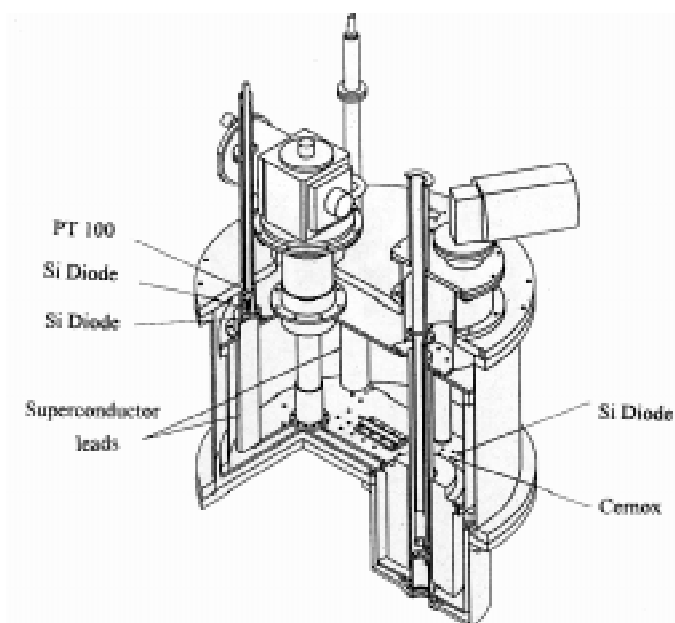
**Figure 2.** Three-dimensional view of the magnet showing its interior parts.

urs at high fields. The coil was wound on a SS drum by adopting the wind and react process. The magnet was protected by using resistors and 12 diodes connected in a back to back configuration. The cryostat has a 52 mm room-temperature bore. A schematic diagram showing the various parts of the magnet is given in Figure 1.

Leads made of 2223 high T_c bismuth cuprate tapes (current carrying capacity 300 amps at 77 K) were connected between the Nb₃Sn coil and the copper end-terminals. The first stage of a GM Sumitomo cryocooler (model SRDK-408 with 1.0 W cooling capacity at 4.2 K) was coupled to the high T_c leads and the second stage was connected to the Nb₃Sn magnet coil. The temperature of the coil was maintained below 4.2 K while energizing the magnet or while de-energizing it at a rate of 0.04 A/sec or lower. Superinsulation of 15 years was provided around the superconducting coil to minimize thermal losses.

Quartz windows of 20 mm diameter provided at the bottom of the magnet coil as well as at the sample holder assembly allow light to pass through. A cryocooler (CTI cryogenics model 8200) and an accompanying 50 W heater permit measurements from 12 K to 500 K, the temperature being measured and controlled by Cernox and PT100 Lakeshore sensors and the temperature controller. A three-dimensional cross-sectional view of the magnet and its accessories is shown in Figure 2.

In the absence of a magnetic field, a coil temperature of less than 3.4 K could be achieved, the temperature of the high T_c leads being below 47 K. When the magnet was energized to 15 T (227.7 A) by using a Cryogenic (Model SMS 240C) 240 A magnet power supply,



Figure 3. Photograph of a fully assembled magnet

Table 2. Specifications of the magnet

Specification	Value
Maximum magnetic field	15.0 T
Energizing current for 15 T	227.7 amps
Homogeneity over 10 mm	0.1%
Total coil inductance	3.4 Henry
Average turn density	180 turns/cm ²
Maximum radial hoop-stress	33 Kpsi
Persistent switch normal resistance	35 ohm
Persistent switch heater resistance	100 ohm

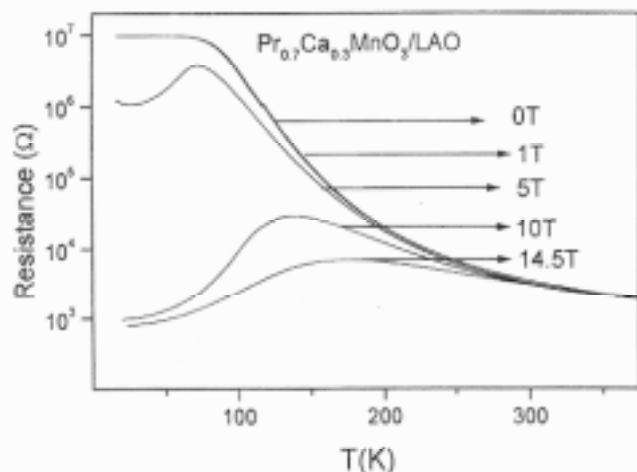

Figure 4. Temperature variation of magnetoresistance of a $\text{Pr}_{0.7}\text{Ca}_{0.3}\text{MnO}_3$ film deposited on LaAlO_3 single crystal substrate for different magnetic fields.

the temperatures of the coil and the leads were 3.5 K and 58 K, respectively. The magnet could be operated at

15 T up to 3 h without quenching. It could be operated continuously at 14.5 T (220 A). The temperature of the coil and the leads are 3.5 K and 58 K, respectively at 14.5 T. We have used silicon diodes as well as Cernox and RTD sensors at crucial places to monitor the temperature of each section and to control the temperature of the measuring sample.

The fully assembled magnet has a height of 112 cm and a diameter of 56 cm. It weighs 150 kg. A photograph of the assembled magnet, in its final working form, is shown in figure 3.

Performance of the magnet

In order to test the performance of the magnet, we have measured the magnetoresistance of polycrystalline as well as thin film samples of rare earth manganates at different fields and at different temperatures. In Figure 4, we show the temperature variation of resistance of an epitaxial thin film of $\text{Pr}_{0.7}\text{Ca}_{0.3}\text{MnO}_3$ deposited on a LaAlO_3 (001) substrate at different magnetic fields. $\text{Pr}_{0.7}\text{Ca}_{0.3}\text{MnO}_3$ is a charge-ordered insulator, with the charge-ordering temperature around 230 K (ref. 8). We see that the magnetic field induces an insulator-metal transition in the film. The material becomes metallic starting from ~ 190 K or down at 14.5 T.

We have operated the magnet for 1700 h. or more continuously and found the performance of the magnet to be satisfactory. Since we completed the fabrication of this magnet, we have come across a paper by *Watanabe et al.*⁹, who have achieved a field of 15 T by employing a three-coil system. The pre-cooling time of the magnet (from room temperature to 3.4 K) was 110 h, while the magnet designed by us takes only 13 h to reach the same temperature.

- Suenaga, M., in *Superconductor Material Science* (eds Foner, S. and Schwartz, B. B.), Plenum Press, New York, 1981, P. 201.
- Jikihara, K., Watazawa, K., Mitsubori, H., Sakuraba, J., Sugizaki, Y., Hasebe, T., Okubo, H., Ishihara, M. and Watanabe, K., *IEEE Trans. Appl. Supercon.*, 1997, 7, 423.
- Watanabe, K., Yamada, Y., Sakuraba, J., Hatai, F., Chang, C. K., Haseh, T. and Ishihara, M., *Jpn. J. Appl. Phys.*, 1993, 32, L488.
- Watanabe, K., Awaji, S. and Kimura, K., *Jpn. J. Appl. Phys.*, 1997, 36, L673.
- Hasebe, K., Mitsubori, H., Sakuraba, J., Ishihara, M., Awaji, S. and Watanabe, K., *IEEE Trans. Appl. Supercon.*, 1997, 7, 707.
- Dew-Hughes, D., *Philos. Mag.*, 1974, 30, 293.
- Turowski, P. and Schneider, Th., *Physica B*, 1989, 155, 87.
- Rao, C. N. R. and Raveau, B. (eds), *Colossal Magnetoresistance, Charge-ordering and Related Properties of Manganese Oxides*, World Scientific, Singapore, 1998.
- Watanabe, K., Awaji, S., Motokawa, M., Mikami, Y., Sakuraba, J. and Watazawa, K., *Jpn. J. Appl. Phys.*, 1998, 37, L1148.

ACKNOWLEDGEMENT. Thanks are due to the Department of Science and Technology, Government of India, for supporting the design and fabrication of the magnet.

Received 8 July 1999; accepted 12 July 1999